

+ **MORE**
FREE SPACE

50%

- **LESS**
SWING SPACE





SOLUTIONS FOR ALL NEEDS

COMPACT living[®] is a revolutionary system that reduces door clearance needs and maximizes usable space. Areas around doorways can be redesigned to make more of the room area usable.

No more problems of conflict between adjacent doors.

The door folds in half against the wall, reducing space needs by 50%. When, the door becomes a single element similar to a normal one-piece door. The door closes against a rabbet on the two sides and across the top.

DOOR SYSTEM

example dimensions with door leaves:

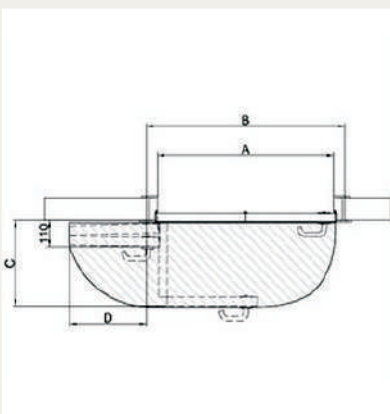

WIDTH

Passage dimension	A	800	900	1000
Wall hole width	B	900	1000	1100
Maximum door swing clearance	C	455	505	555
Maximum space needed by fully open door	D	345	395	445



PERFECT FOR ALL NEEDS HOLLOW OR SOLID CORE

Compact hardware has been designed for installation on traditional folding door panels and on any structural fitting of the panel.

COMPACT living[®] is a kit that will revolutionize your concept of door. It opens up new interior design frontiers, making more space available in cramped quarters.

COMPACT living[®] is a functional alternative to all types of doors.

No modification of the walls is necessary.

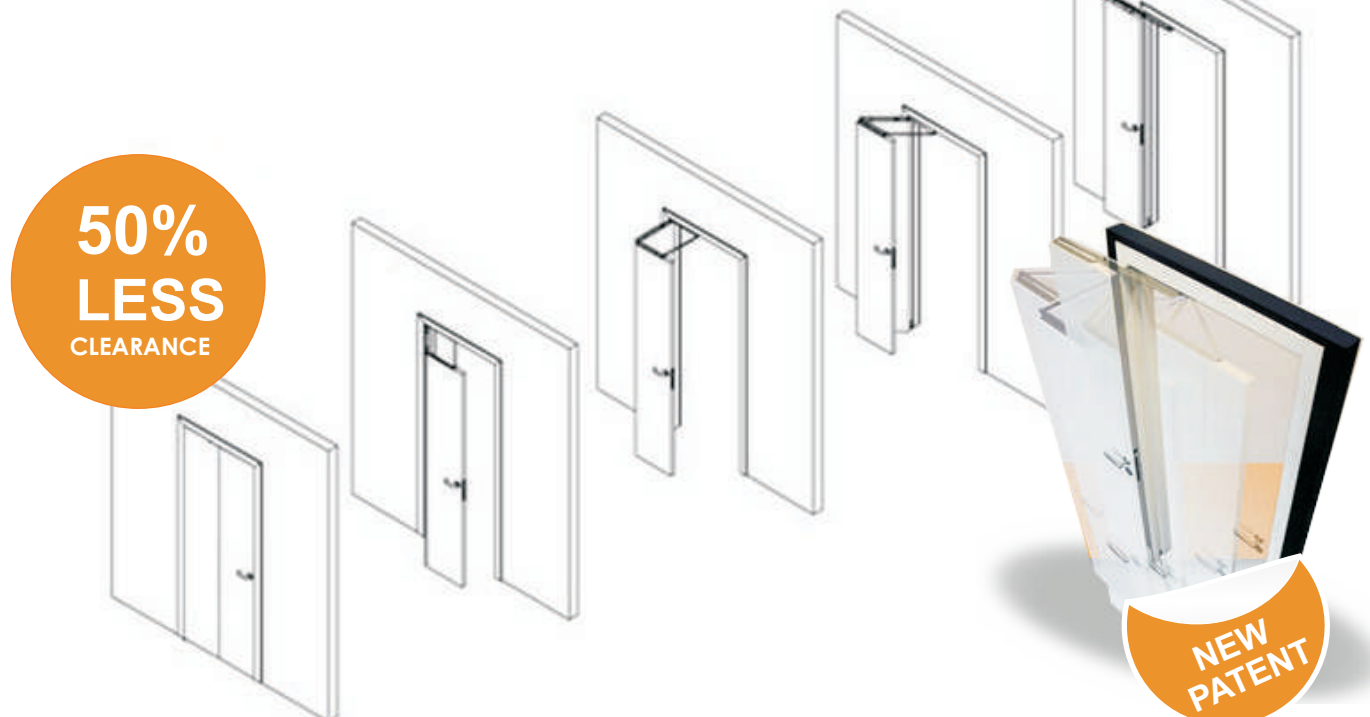

BENZOVILLE

HARDWARE

PATENTED MADE in ITALY

AN EXCLUSIVE CELEGON PRODUCT

COMPACK[®] living is a door technology that opens up new interior design frontiers, making more space available even in cramped quarters.

COMPACK living[®] is a functional alternative to all types of door. No modifications to walls are necessary. There are no sliding or rolling members, the door moves fluidly without a sound. Prolonged use does not compromise the quality of the movement.



LONG-LASTING RELIABILITY

COMPACK living[®] provides a stable, silent and ergonomic door movement.

The door closes against a rabbet on three sides, ensuring an excellent acoustic seal.

A TECHNOLOGY ADAPTABLE TO EVERY SITUATION

No modifications to walls and no added costs with respect to more traditional door system: **COMPACK** living[®] is an excellent choice, and also economical thanks to the easy-to-use kits.

BENZOVILLE HARDWARE DOOR CUT SWING SPACE IN HALP

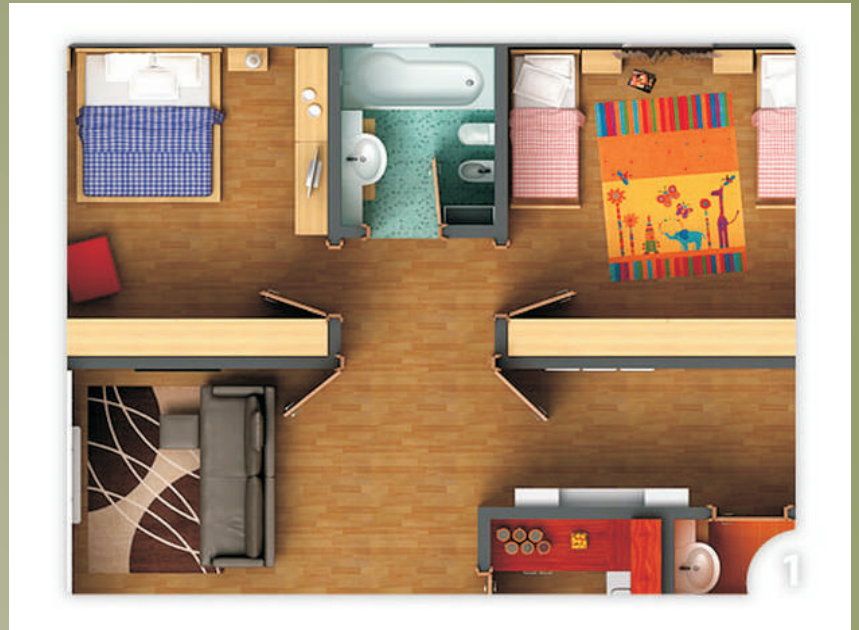

AND SMALL SPACES GET BIGGER

Constantly dedicated to product innovation, Celegon introduces **COMPACT** living[®] a door technology developed through the contributions of one of the most brilliant and successful Italian designers, Massimo Bonetti. Like the Ergon rototranslating technology, the **COMPACT** living[®] system represents another technicalation that can reduce door clearance needs by up to 50%. **COMPACT** living[®] makes it possible to design previously impossible layouts, opening up new possibilities in space usage and new furnishing possibilities even in cramped quarters.



Layout 1 a floor plan using normal swinging door.
Layout 2 **COMPACT** living[®] system makes it possible to significantly increase usable space in a given floor plan and eliminate conflict between adjacent door.



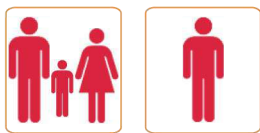

MADE IN ITALY



BENZOVILLE
HARDWARE



Delhi:

59-B, Arjun Nagar, Kotla, Timber Market (Near Jawala Prasad & Co.)
Opp. Defence Colony, New Delhi-110003
t : +91-24655704, 41554595, 65653041, m : +91-9310406140

Gurgaon :

117, Grand Mall, M.G. Road Gurgaon
t : +91-124-4375376 m: +91-9310406170

e-mail: uniqueinnovations@gmail.com
www.benzoville.com